

Baseline Traffic

 % HGVs
 Vehicle Count

Notes
 Survey undertaken over 24 hours per day between 15/03/23-21/03/23.
 Diagram represents the 7 day average.

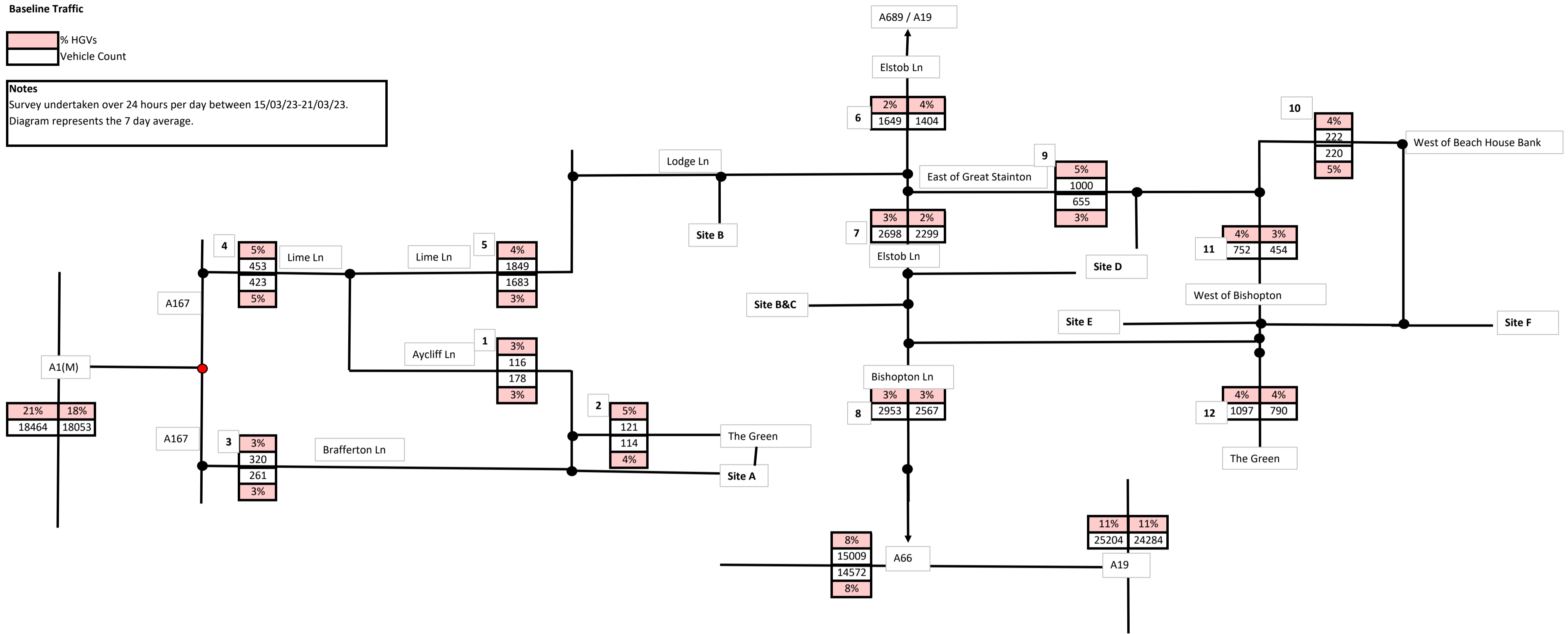

Future Baseline

 Vehicle Count

Notes
 Survey undertaken over 24 hours per day between 15/03/23-21/03/23.
 Diagram represents the 7 day average.
 Future Baseline consists of Survey data plus committed trips

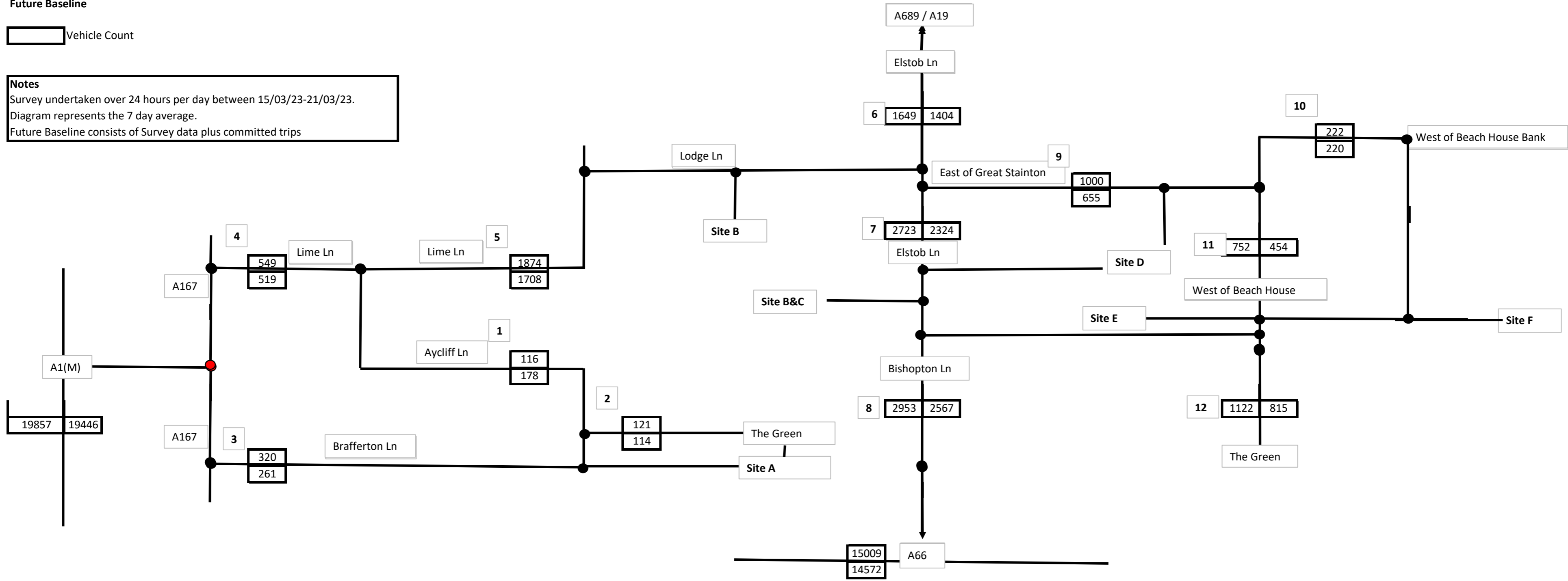

Construction Traffic

% HGVs
 Vehicle Count

Notes
 Construction traffic is routed based on quickest available route to the SRN (excluding Site E and F).
 Diagram shows a maximum of 3 sites worth of traffic on each road to represent the worst case scenario.

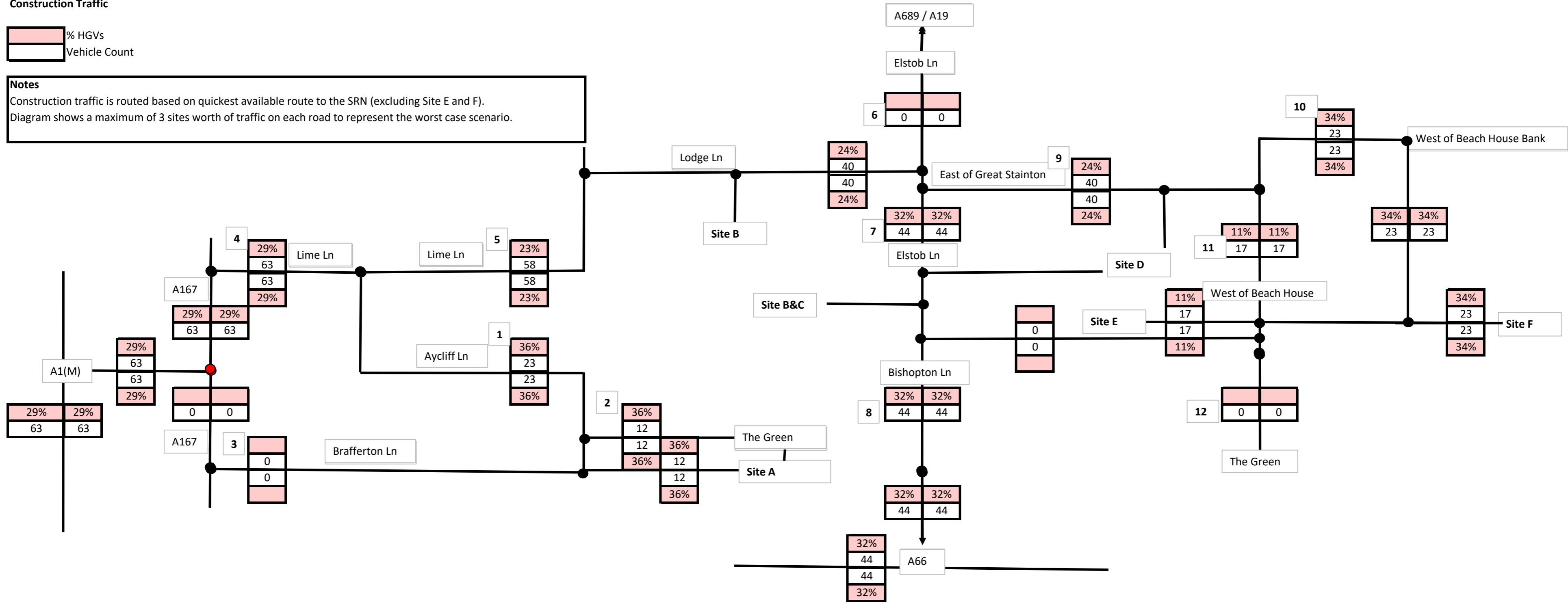

Future Traffic

 Vehicle Count

Notes
 Survey undertaken over 24 hours per day between 15/03/23-21/03/23.
 Diagram represents the 7 day average.
 Future traffic during construction including baseline and committed trips

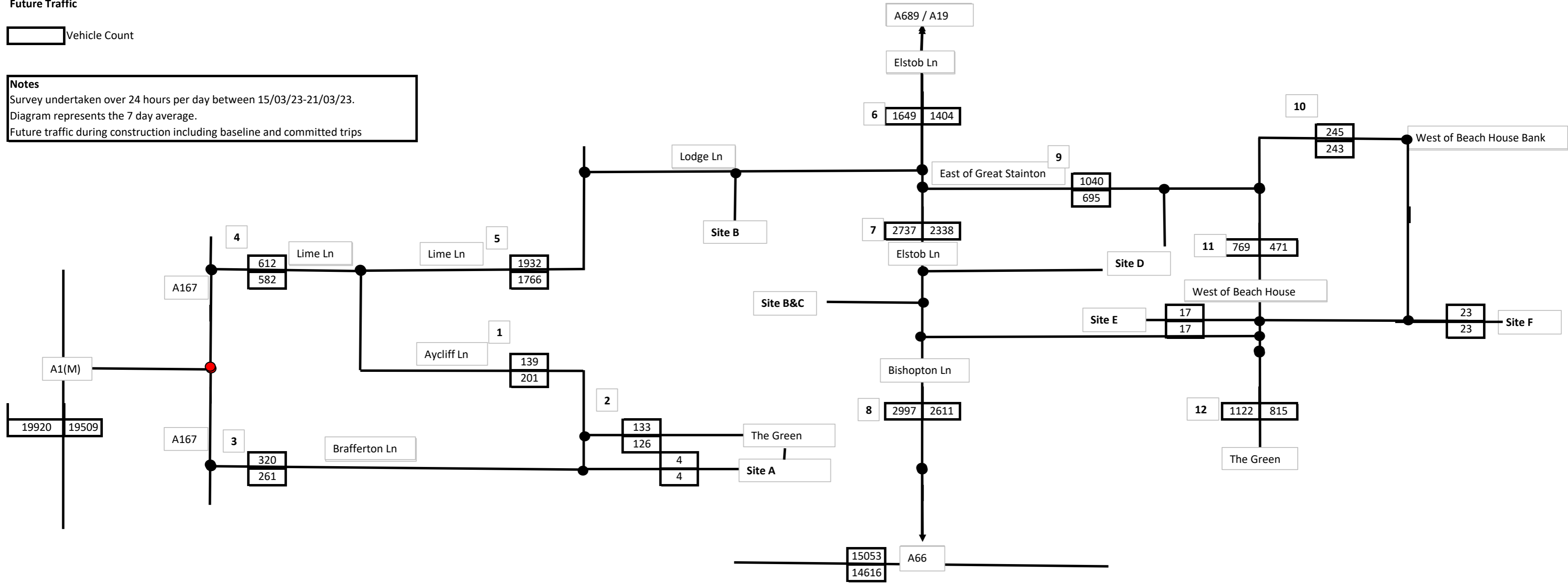

Construction Traffic Percentage Change

Vehicle Count

Notes
Percentage change in vehicle numbers from the future baseline

